

### 2 Post Rack Grommet

Part Number  
10123



#### Carton Contains:

- Part No. 20170 Brush Holder Mounting Extrusion (2)
- Part No. 20172 Sealing Brushes (2)
- Part No. 20171 End Caps (2)

### Installation instructions

#### 2 Post Rack Grommet

1. Slide brush into plastic extrusion (2X).
2. Center brush in plastic extrusion (2X).
3. Slide brush assembly onto rack supportflange (2X).
4. Slide end cap hooks into plastic extrusion channels (2X).

#### ! SAFETY REQUIREMENTS

Installers must be familiar with standard safety and risk management practices when working in raised-floor environments and when modifying floor tiles.

#### Effective Installation of Cables

In order to minimize any air loss from the rack hole selection, make sure to allow for adequate slack in the cables. If the cables are under too much tension, the grommet may be pulled apart, resulting in a gap that will cause an increase in the flow of air escaping through the rack.

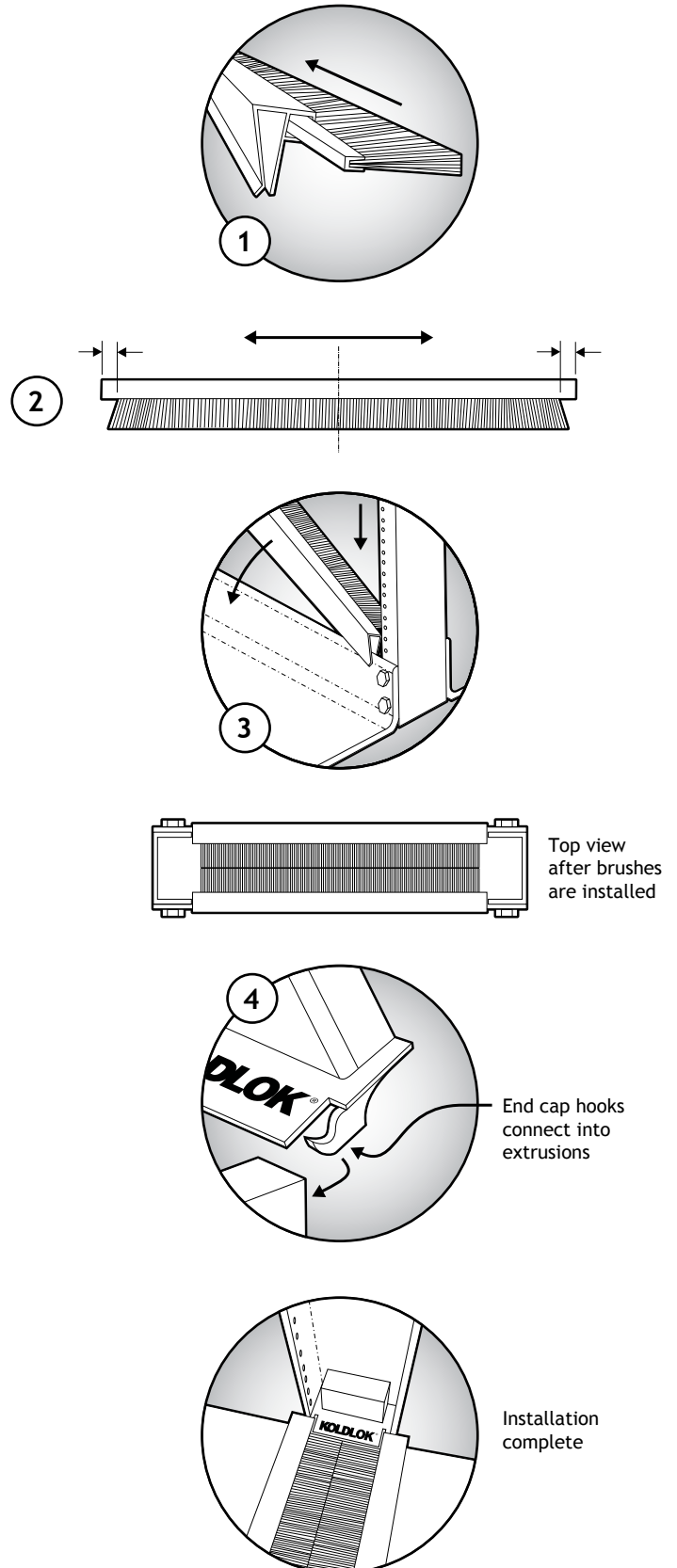

# Installation Guide

## Limited Warranty

Upsite Technologies, Inc. (the *Company*) warrants to the original purchaser that products delivered hereunder will be free of defects in materials and workmanship for a period of twelve (12) months from the date of purchase (the "Warranty Period").

The *Company* shall, at its option, within the Warranty Period, either repair or replace free of charge, any product or part thereof found, upon the *Company's* inspection, to be defective in materials and workmanship, and will return the repaired or replaced product to the purchaser at *Company's* expense.

For warranty service and shipping instructions, contact the *Company* at the telephone number shown below. If the product is under warranty and the defect appears to be covered by this Limited Warranty, the *Company* will issue to the purchaser a Notice of Authorization For Warranty Return. Products returned to the *Company* for warranty service must be accompanied by a statement of defect, the Notice of Authorization for Warranty Return provided by the *Company*, and proof of purchase.

This Limited Warranty is conditioned on the following:

1. The *Company* must be notified within 12 months of purchase and have been given the opportunity of inspection by return of any alleged defective product free and clear of all liens and encumbrances to the *Company* or its manufacturer; and
2. The product must not have been abused, misused, or improperly maintained, and/or repaired during such period; and
3. Such defect has not been caused by corrosion or exposure to other than ordinary wear and tear; and
4. The installation and use of the product has been in accordance with the manufacturer's instructions and not been modified or customized to include but not limited to cut, resized, burned, glued, bent, re-shaped, disassembled, attachments added to, improperly installed or used in a manner other than intended.

The company makes no other express or implied warranty or representation of any kind whatsoever including any warranty of merchantability or fitness for a particular purpose and all such other warranties are hereby included.

The Company's maximum liability hereunder is limited to the purchase price of the product. In no event shall the Company be liable for any consequential, indirect, incidental, or special damages of any nature arising from the sale or use of the product, whether based in contract, tort, strict liability, or otherwise.

Note: Some jurisdictions do not allow limitations on incidental or consequential damages or how long an implied warranty lasts, so that the above limitations may not fully apply. This warranty gives specific legal rights and you may also have other rights which may vary from jurisdiction to jurisdiction.

For complete warranty and repair information Call (888) 982-7800 or visit [upsite.com](http://upsite.com)

U.S. Patent No. 6,632,999 and International Patents Pending

**For Sales and Installation, contact:**

The logo for Data Clean features a stylized globe icon on the left, followed by the word "Data" in a bold, blue, sans-serif font, and the word "Clean" in a larger, blue, sans-serif font with a registered trademark symbol. Below the logo, the phone number (800) 328-2256 and the website www.dataclean.com are listed, separated by a bullet point.  
(800) 328-2256 • [www.dataclean.com](http://www.dataclean.com)