

### 1010, 4040 Cover with Safety Stripe

Covers Part Number:

10187

The 10-pack carton contains:

(10) KoldLok<sup>®</sup> Raised Floor Grommet Covers



### SAFETY REQUIREMENTS

Installers must be familiar with standard safety and risk management practices when working on server rack equipment or in data center environments.

### KoldLok<sup>®</sup> Raised Floor Grommet Cover

Part Number	Inches	Millimeters
10187	8.75" x 5.63" x .09"	222.25 mm x 143 mm x 2.29 mm

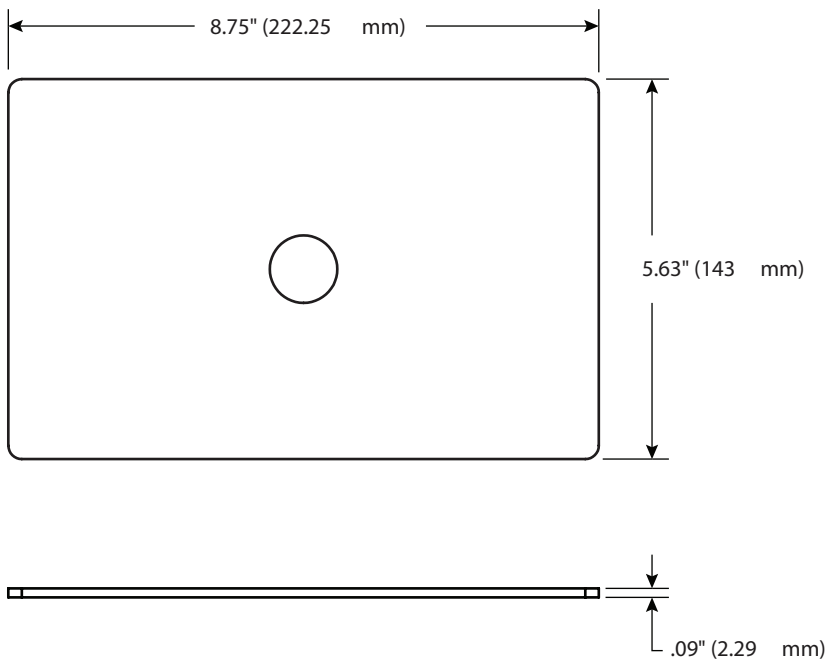

For Sales and Installation, contact:



(800) 328-2256 • [www.dataclean.com](http://www.dataclean.com)

### Installation Instructions

KoldLok<sup>®</sup> Raised Floor Grommet Covers

1. Remove the KoldLok<sup>®</sup> Cover(s) from the shipping carton and plastic bag(s).
2. Determine whether or not you want the safety stripe or solid black side facing upwards.
3. Install the KoldLok<sup>®</sup> Cover by placing inside over the inner lip of the KoldLok<sup>®</sup> 1010, or 4040 Grommet.

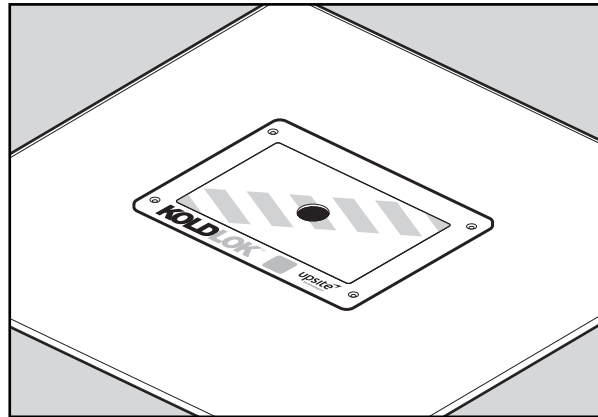
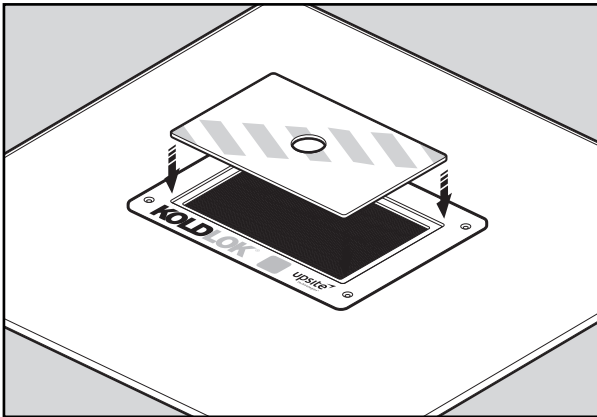

**For Sales and Installation, contact:**



(800) 328-2256 • [www.dataclean.com](http://www.dataclean.com)

# Installation Guide

## Limited Warranty

Upsite Technologies, Inc. (the Company ) warrants to the original purchaser that products delivered hereunder will be free of defects in materials and workmanship for a period of twelve (12) months from the date of purchase (the "Warranty Period").

The Company shall, at its option, within the Warranty Period, either repair or replace free of charge, any product or part thereof found, upon the Company's inspection, to be defective in materials and workmanship, and will return the repaired or replaced product to the purchaser at Company's expense.

For warranty service and shipping instructions, contact the Company at the telephone number shown below. If the product is under warranty and the defect appears to be covered by this Limited Warranty, the Company will issue to the purchaser a Notice of Authorization For Warranty Return. Products returned to the Company for warranty service must be accompanied by a statement of defect, the Notice of Authorization for Warranty Return provided by the Company , and proof of purchase.

This Limited Warranty is conditioned on the following:

1. The Company must be notified within 12 months of purchase and have been given the opportunity of inspection by return of any alleged defective product free and clear of all liens and encumbrances to the Company or its manufacturer; and
2. The product must not have been abused, misused, or improperly maintained, and/or non-Upsite authorized repair performed during such period; and
3. Such defect has not been caused by corrosion or exposure to other than ordinary wear and tear; and
4. The installation and use of the product has been in accordance with the manufacturer's instructions and not been modified or customized to include but not limited to cut, resized, burned, glued, bent, re-shaped, disassembled, attachments added to, improperly installed or used in a manner other than intended.

The company makes no other express or implied warranty or representation of any kind whatsoever including any warranty of merchantability or fitness for a particular purpose and all such other warranties are hereby included.

The Company's maximum liability hereunder is limited to the purchase price of the product. In no event shall the Company be liable for any consequential, indirect, incidental, or special damages of any nature arising from the sale or use of the product, whether based in contract, tort, strict liability, or otherwise.

Note: Some jurisdictions do not allow limitations on incidental or consequential damages or how long an implied warranty lasts, so that the above limitations may not fully apply. This warranty gives specific legal rights and you may also have other rights which may vary from jurisdiction to jurisdiction.

For complete warranty and repair information Call (888) 982-7800 or visit [upsite.com](http://upsite.com)

U.S. and International Patents Pending.



Designer and Manufacturer  
888.982.7800  
[www.upsite.com](http://www.upsite.com)

**For Sales and Installation, contact:**



(800) 328-2256 • [www.dataclean.com](http://www.dataclean.com)